



Technical Bulletin

Subject: Front Suspension, Noisy

Group: 40

Model(s): A4
A6
A8

1996 >
1998 >
1997 >

Number: 98-02

Date: Sept. 3, 1998

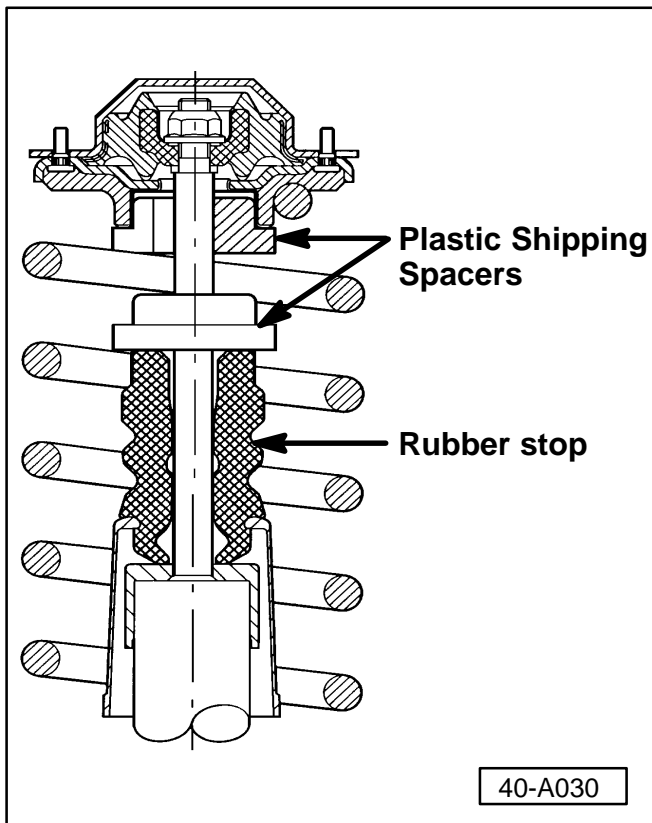

Condition

Clunking or rattling noise from one or both sides of front suspension when driving over rough roads.

May be caused by shipping spacers not being removed during the Pre-Delivery Inspection.

Service

- Raise vehicle on hoist.
- ◀ - Check that all shipping spacers (**two per side**) were removed during the Pre-Delivery Inspection.

Note:

Spacers are installed to protect the vehicle during shipping.

Discard spacers after removal.

- Road test vehicle after spacer removal.
- ◆ During the road test, rubber stop should slip into spring seat on the first jounce.

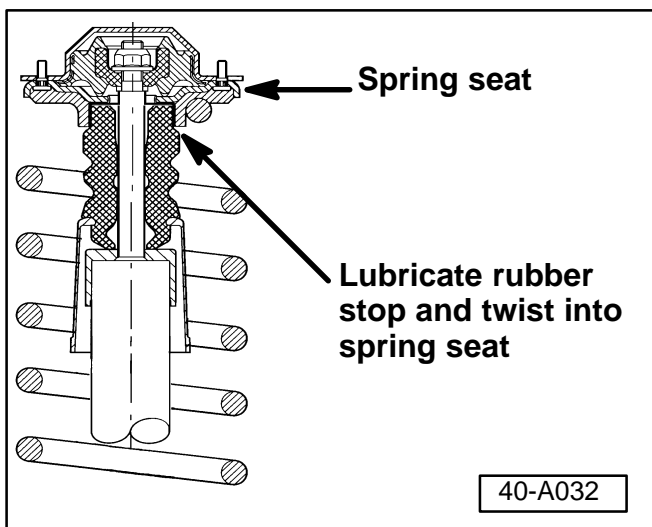

- ◀ - After road test, inspect rubber stop for proper positioning:

If stop is not properly positioned into spring seat:

- Lubricate upper edge of rubber stop with silicone grease/spray (acid free) and twist stop into the spring seat manually.